

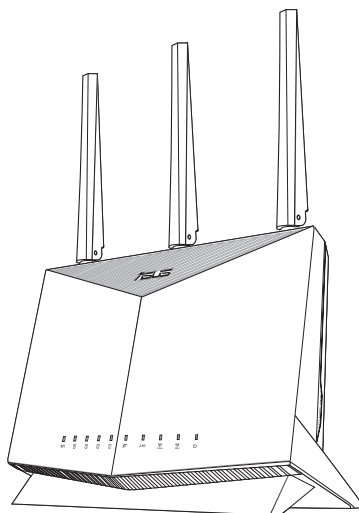

RT-AX86U

Wireless-AX5700 Dual-band Gigabit Router



Quick Start Guide

Q16249a / First Edition / July 2020

Table of contents

Package contents	3
A quick look at RT-AX86U	3
Position your wireless router	4
Preparing your modem	5
Setting up your RT-AX86U	6
A. Wired connection	6
B. Wireless connection.....	6
FAQ	8
Networks Global Hotline Information	27

This QSG contains these languages:

English
Français
Português
Español

Package contents

- ☑ RT-AX86U Wireless Router
- ☑ Network cable (RJ-45)
- ☑ AC adapter
- ☑ Quick Start Guide

A quick look at RT-AX86U

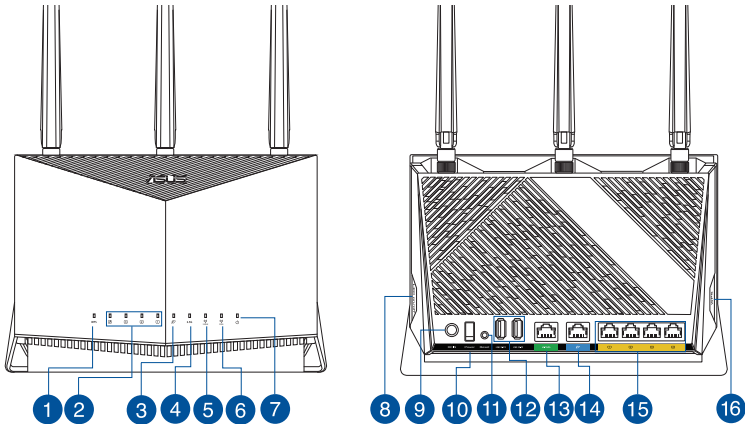

1 WPS LED	9 Power (DC-IN) port
2 LAN 1~4 LEDs	10 Power button
3 WAN (Internet) LED	11 Reset button
4 2.5G LED	12 USB 3.2 Gen 1 ports
5 2.4GHz LED	13 2.5G port
6 5GHz LED	14 WAN (Internet) port
7 Power LED	15 LAN 1 ~ 4 ports
8 LED on/off button	16 WPS button

Position your wireless router

For optimal wireless transmission between the wireless router and connected wireless devices, ensure that you:

- Place the wireless router in a centralized area for a maximum wireless coverage for the network devices.
- Keep the wireless router away from metal obstructions and away from direct sunlight.
- Keep the wireless router away from 802.11g or 20MHz only Wi-Fi devices, 2.4GHz computer peripherals, Bluetooth devices, cordless phones, transformers, heavy-duty motors, fluorescent lights, microwave ovens, refrigerators, and other industrial equipment to prevent signal interference or loss.
- Always update to the latest firmware. Visit the ASUS website at <http://www.asus.com> to get the latest firmware updates.
- Orient the antennas as shown in the drawing below.

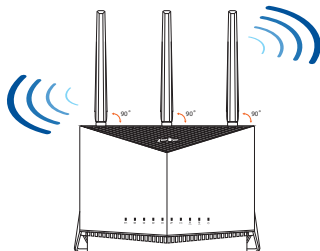

NOTES:

- Use only the adapter that came with your package. Using other adapters may damage the device.
- **Specifications:**

DC Power adapter	DC Output: +19V with 2.37A current DC Output: +19.5V with 2.31A current		
Operating Temperature	0~40°C	Storage	0~70°C
Operating Humidity	50~90%	Storage	20~90%

Preparing your modem

1. **Unplug the power cable/DSL modem. If it has a battery backup, remove the battery.**

NOTE: If you are using DSL for Internet, you will need your username/password from your Internet Service Provider (ISP) to properly configure the router.

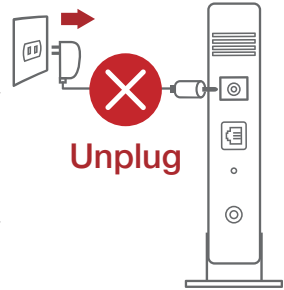

2. **Connect your modem to the router with the bundled network cable.**

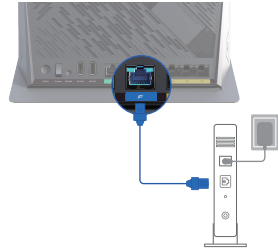

3. **Power on your cable/DSL modem.**
4. **Check your cable/DSL modem LED lights to ensure the connection is active.**

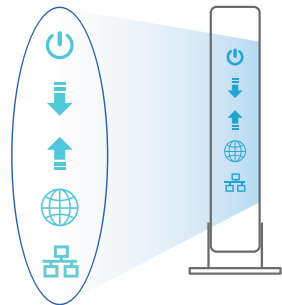

Setting up your RT-AX86U

You can set up your router via wired or wireless connection.

A. Wired connection

1. Plug your router into a power outlet and power it on. Connect the network cable from your computer to a LAN port on your router.

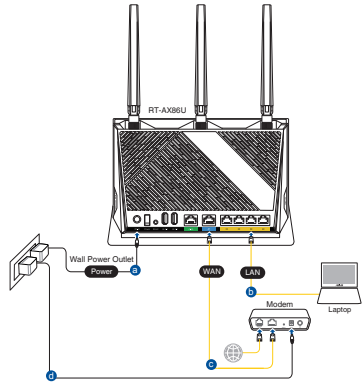

2. The web GUI launches automatically when you open a web browser. If it does not auto-launch, enter <http://router.asus.com>.
3. Set up a password for your router to prevent unauthorized access.

Login Information Setup

Change the router password to prevent unauthorized access to your ASUS wireless router.

Router Login Name	<input type="text" value="admin"/>
New Password	<input type="password"/>
Retype Password	<input type="password"/> <input type="checkbox"/> Show password

B. Wireless connection

1. Plug your router into a power outlet and power it on.

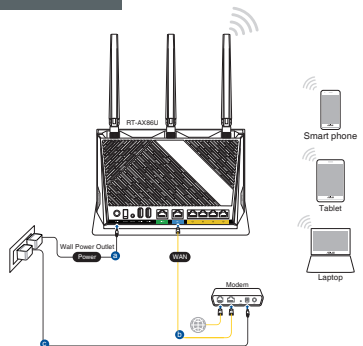

2. **Connect to the network with SSID shown on the product label on the back side of the router. For better network security, change to a unique SSID and assign a password.**

Wi-Fi Name (SSID):	ASUS_XX
--------------------	---------

- * **XX** refers to the last two digits of 2.4GHz MAC address. You can find it on the label on the back of your router.

3. **You can choose either the web GUI or ASUS Router app to set up your router.**

- a. **Web GUI Setup**

- **Once connected, the web GUI launches automatically when you open a web browser. If it does not auto-launch, enter <http://router.asus.com>.**
- **Set up a password for your router to prevent unauthorized access.**

Login Information Setup

Change the router password to prevent unauthorized access to your ASUS wireless router.

Router Login Name	<input type="text" value="admin"/>
New Password	<input type="password"/>
Retype Password	<input type="password"/> <input type="checkbox"/> Show password

b. App Setup

Download ASUS Router App to set up your router via your mobile devices.

- Turn on Wi-Fi on your mobile devices and connect to your router's network.
- Follow ASUS Router App setup instructions to complete the setup.



ASUS
Router



Remembering your wireless router settings

- Remember your wireless settings as you complete the router setup.

Router Name:	Password:
2.4 GHz network SSID:	Password:
5GHz network SSID:	Password:

FAQ

1. Where can I find more information about the wireless router?
 - Technical support site: <https://www.asus.com/support>
 - Customer hotline: refer to the Support Hotline section in this Quick Start Guide
 - You can get the user manual online at <https://www.asus.com/support>

Contenu de la boîte

- ☑ Routeur Wi-Fi RT-AX86U
- ☑ Câble réseau (RJ-45)
- ☑ Adaptateur secteur
- ☑ Guide de démarrage rapide

Aperçu rapide de votre routeur RT-AX86U

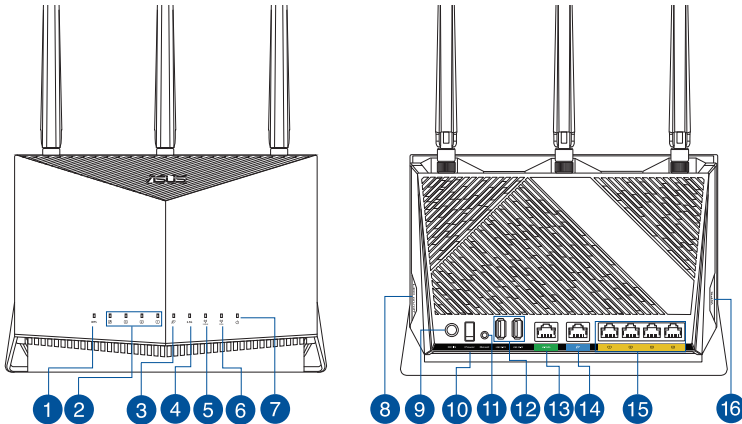

1	Voyant WPS	9	Port d'alimentation (CC)
2	Voyants réseau local (LAN) 1 à 4	10	Bouton d'alimentation
3	Voyant réseau étendu (WAN) (Internet)	11	Bouton de réinitialisation
4	Voyant LED 2.5G	12	Ports USB 3.2 Gen1
5	Voyant de bande 2,4 GHz	13	Port 2.5G
6	Voyant de bande 5 GHz	14	Port réseau étendu (WAN) (Internet)
7	Voyant d'alimentation	15	Ports réseau local (LAN) 1 à 4
8	Bouton LED	16	Bouton WPS

Placer le routeur Wi-Fi

Pour optimiser la transmission du signal Wi-Fi entre votre routeur et les périphériques réseau y étant connectés, veuillez vous assurer des points suivants :

- Placez le routeur Wi-Fi dans un emplacement central pour obtenir une couverture Wi-Fi optimale.
- Maintenez le routeur à distance des obstructions métalliques et des rayons du soleil.
- Maintenez le routeur à distance d'appareils ne fonctionnant qu'avec les normes/fréquences Wi-Fi 802.11g ou 20MHz, les périphériques 2,4 GHz et Bluetooth, les téléphones sans fil, les transformateurs électriques, les moteurs à service intense, les lumières fluorescentes, les micro-ondes, les réfrigérateurs et autres équipements industriels pour éviter les interférences ou les pertes de signal Wi-Fi.
- Mettez toujours le routeur à jour dans la version de firmware la plus récente. Visitez le site Web d'ASUS sur <http://www.asus.com> pour consulter la liste des mises à jour.
- Orientez les antennes comme sur l'illustration ci-dessous.

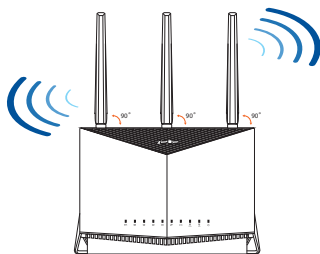

REMARQUES :

- Utilisez uniquement l'adaptateur secteur fourni avec votre appareil. L'utilisation d'autres adaptateurs peut endommager l'appareil.
- **Caractéristiques**

Adaptateur secteur CC	Sortie CC : +19V (max 2,37A) Sortie CC : +19,5V (2,31A)		
Température de fonctionnement	0-40°C	Stockage	0-70°C
Humidité de fonctionnement	50-90 %	Stockage	20-90 %

Préparer votre modem

1. **Débranchez le câble d'alimentation / le modem DSL. Si votre modem possède une batterie de secours, retirez-la.**

REMARQUE : Si vous utilisez le DSL pour accéder à Internet, vous aurez besoin du nom d'utilisateur et du mot de passe fournis par votre fournisseur d'accès internet (FAI) pour configurer votre routeur.

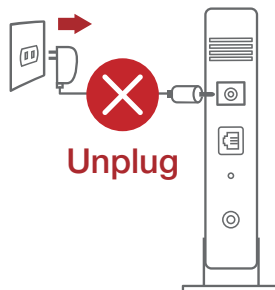

2. **Raccordez votre modem au routeur à l'aide du câble réseau fourni.**



3. **Allumez votre modem câble/DSL.**
4. **Vérifiez les voyants lumineux de votre modem câble/DSL pour vous assurer que la connexion est établie.**

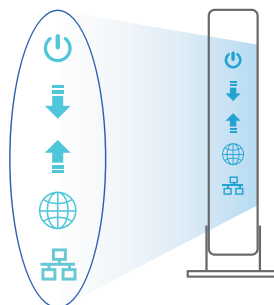

Configurer votre RT-AX86U

Vous pouvez configurer votre routeur via une connexion filaire ou Wi-Fi.

A. Connexion filaire

1. Branchez le routeur sur une prise électrique, puis allumez-le. Utilisez le câble réseau pour relier votre ordinateur au port de réseau local (LAN) du routeur.

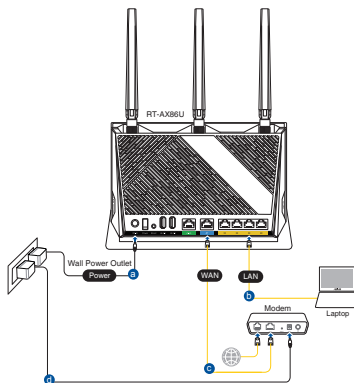

2. L'interface de gestion du routeur s'affiche automatiquement lors de l'ouverture de votre navigateur internet. Si ce n'est pas le cas, entrez <http://router.asus.com> dans la barre d'adresse..
3. Définissez un mot de passe afin d'éviter les accès non autorisés au routeur.

Login Information Setup

Change the router password to prevent unauthorized access to your ASUS wireless router.

Router Login Name	<input type="text" value="admin"/>
New Password	<input type="password"/>
Retype Password	<input type="password"/> <input type="checkbox"/> Show password

B. Connexion Wi-Fi

1. Branchez le routeur sur une prise électrique, puis allumez-le.

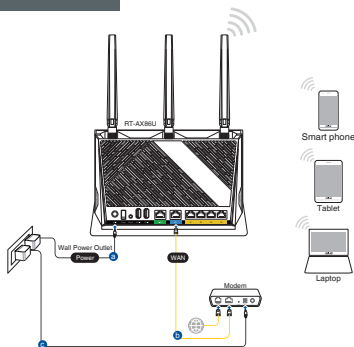

2. **Connectez-vous au réseau dont le nom (SSID) est affiché sur l'étiquette du produit située à l'arrière du routeur. Pour garantir une plus grande sécurité, modifiez le nom du réseau et le mot de passe.**

Nom du réseau Wi-Fi (SSID) : ASUS_XX

- * **XX** correspond aux deux derniers chiffres de l'adresse MAC 2,4 GHz. Vous pouvez les trouver sur l'étiquette située à l'arrière de votre routeur.

3. **Vous pouvez choisir de configurer votre routeur à l'aide de l'interface de gestion ou de l'application ASUS Router.**

- a. **Configuration via l'interface de gestion**

- **Une fois connecté, l'interface de gestion du routeur s'affiche automatiquement lors de l'ouverture de votre navigateur internet. Si ce n'est pas le cas, entrez <http://router.asus.com> dans la barre d'adresse.**
- **Définissez un mot de passe afin d'éviter les accès non autorisés au routeur.**

Login Information Setup

Change the router password to prevent unauthorized access to your ASUS wireless router.

Router Login Name

New Password

Retype Password Show password

b. Configuration via l'application

Téléchargez l'application ASUS Router pour configurer votre routeur par le biais de vos appareils mobiles.

- **Activez le Wi-Fi sur vos appareils mobiles et connectez-vous au réseau du routeur.**
- **Suivez les instructions de configuration de l'application ASUS Router pour effectuer la configuration.**



ASUS
Router



Se rappeler des paramètres de votre routeur Wi-Fi

- **Notez les paramètres Wi-Fi choisis lors de la configuration de votre routeur.**

Nom du routeur :	Mot de passe :
2.4 Nom du réseau de 2,4 GHz (SSID) :	Mot de passe :
Nom du réseau de 5 GHz (SSID) :	Mot de passe :

FAQ

1. Où puis-je obtenir plus d'informations sur le routeur Wi-Fi ?
 - Site de support technique : <https://www.asus.com/support>
 - Service clientèle : consultez la liste des centres d'appel ASUS en fin de guide
 - Vous pouvez consulter le manuel de l'utilisateur en ligne à l'adresse suivante : <https://www.asus.com/support>

Conteúdo da embalagem

- ✓ RT-AX86U
- ✓ Cabo de rede (RJ-45)
- ✓ Transformador
- ✓ Guia de consulta rápida

Visão geral do seu RT-AX86U

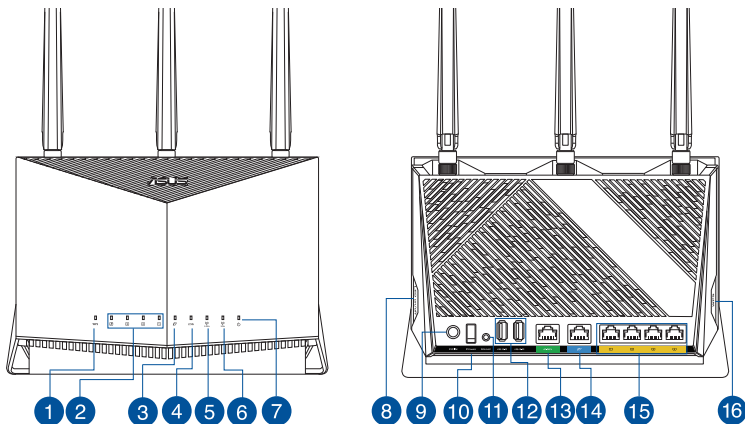

1 WPS LED	9 Porta de alimentação (Entrada DC)
2 LED 1 a 4 da LAN	10 Botão Alimentação
3 LED WAN (Internet)	11 Vypínaè
4 LED 2,5G	12 Portas USB 3.2 Geral 1
5 LED 2,4GHz	13 Porta 2,5G
6 LED 5GHz	14 Porta WAN (Internet)
7 LED de Alimentação	15 LED 1 a 4 da LAN
8 LED on/off button	16 Botão WPS

Colocação do router

Para garantir a melhor qualidade de transmissão entre o router sem fios e os dispositivos de rede a ele ligados:

- Coloque o router sem fios numa área central para obter a maior cobertura possível sem fios para os seus dispositivos de rede.
- Mantenha o dispositivo afastado de obstruções de metal e de luz solar directa.
- Mantenha o dispositivo afastado de dispositivos Wi-Fi que utilizam apenas a norma 802.11g ou 20MHz, periféricos de computador que utilizam a banda 2,4GHz, dispositivos Bluetooth, telefones sem fios, transformadores, motores de alta resistência, lâmpadas fluorescentes, fornos microondas, frigoríficos e outros equipamentos industriais para evitar interferências ou perdas de sinal.
- Actualize sempre para o firmware mais recente. Visite o Web site da ASUS em <http://www.asus.com> para obter as actualizações de firmware mais recentes.
- Oriente as antenas tal como ilustrado nas imagens abaixo.

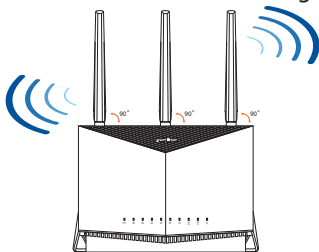

NOTAS:

- Utilize apenas o transformador fornecido com o produto. A utilização de outro transformador poderá danificar o dispositivo.
- **Especificações:**

Transformador DC	Saída DC: +19V com corrente máx. de 2,37A Saída DC: +19,5V com corrente máx. de 2,31A;		
Temperatura de funcionamento	0~40°C	Armazenamento	0~70°C
Humidade em funcionamento	50~90%	Storage	20~90%

Preparar o modem

1. **Desligue o modem por cabo/DSL. Se o mesmo tiver uma bateria de reserva, remova-a.**

NOTA: Se estiver a utilizar uma ligação DSL para aceder à Internet, precisará dos dados de nome de utilizador/palavra-passe fornecidos pelo seu fornecedor de serviços de Internet (ISP) para configurar corretamente o seu router.

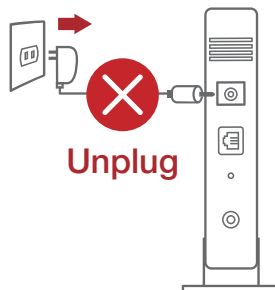

2. **Ligue o seu modem ao router com o cabo de rede fornecido.**

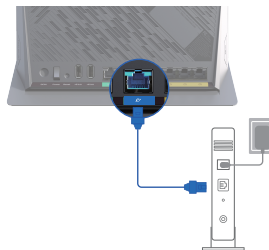

3. **Ligue o seu modem por cabo/DSL.**
4. **Verifique as luzes LED do modem por cabo/DSL para se certificar que a ligação está ativa.**

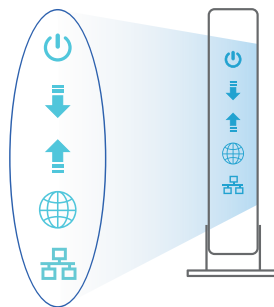

Configurar o RT-AX86U

É possível configurar o RT-AX86U através de uma ligação com ou sem fios.

A. Ligação com fios

1. Ligue o router a uma tomada elétrica e prima o botão de energia. Ligue o cabo de rede do computador a uma porta LAN do router.

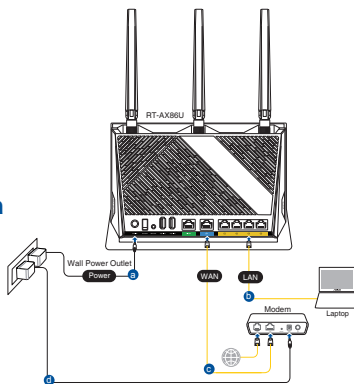

2. A interface web abre automaticamente quando abrir um navegador web. Se não abrir automaticamente, introduza <http://router.asus.com>.
3. Configure uma palavra-passe para o seu router para impedir o acesso não autorizado.

Login Information Setup

Change the router password to prevent unauthorized access to your ASUS wireless router.

Router Login Name	<input type="text" value="admin"/>
New Password	<input type="password"/>
Retype Password	<input type="password"/> <input type="checkbox"/> Show password

B. Ligação sem fios

1. Ligue o router a uma tomada elétrica e prima o botão de energia.

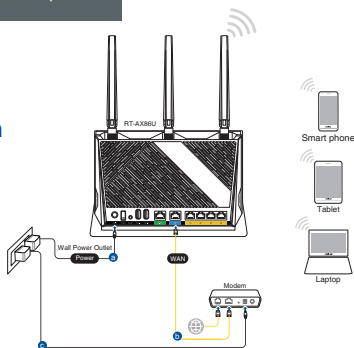

2. **Ligue ao nome de rede (SSID) indicado na etiqueta do produto colada na traseira do router. Para uma maior segurança de rede, mude para um SSID exclusivo e defina uma palavra-passe.**

Nome da rede Wi-Fi (SSID):	ASUS_XX
----------------------------	---------

* **XX** refere-se aos dois últimos dígitos do endereço MAC 2,4GHz. Pode encontrar esse endereço na etiqueta na traseira do RT-AX86U.

3. **Pode escolher a interface Web ou a aplicação ASUS Router para configurar o seu router.**

- a. **Configuração com a interface Web**

- **Após a ligação, a interface web irá abrir automaticamente quando abrir um navegador web. Se não abrir automaticamente, introduza <http://router.asus.com>.**
- **Configure uma palavra-passe para o seu router para impedir o acesso não autorizado.**

Login Information Setup

Change the router password to prevent unauthorized access to your ASUS wireless router.

Router Login Name

New Password

Retype Password Show password

b. Configuração com a aplicação

Transfira a aplicação ASUS Router para configurar o seu router através de dispositivos móveis.

- **Ative a rede Wi-Fi nos seus dispositivos móveis e ligue à rede do RT-AX86U.**
- **Siga as instruções de configuração da aplicação ASUS Router para concluir a configuração.**



ASUS
Router



Memorizar as definições do seu router sem fios

- **Memorize as suas definições de ligação sem fios quando terminar a configuração do router.**

Nome do router:	palavra-passe:
SSID da rede 2,4 GHz:	palavra-passe:
SSID da rede 5GHz:	palavra-passe:

Perguntas Frequentes

1. Onde posso encontrar mais informações acerca do router sem fios?
 - Site de Apoio Técnico: <https://www.asus.com/support>
 - Linha de Apoio ao Cliente: Consulte a Linha de Apoio ao Cliente no Guia suplementar
 - Pode obter o manual online em <https://www.asus.com/support>

Contenido del paquete

- ✓ RT-AX86U
- ✓ Cable de red
- ✓ AC adapter
- ✓ Guía de inicio rápido

Un vistazo rápido a su RT-AX86U

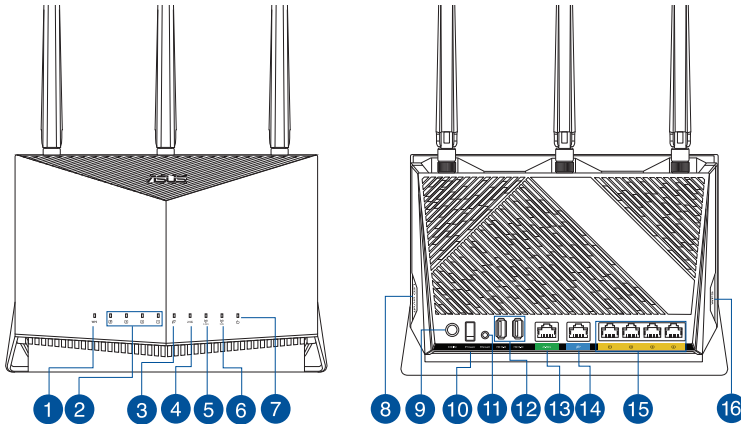

1 LED WPS	9 Puerto de alimentación (DC-IN)
2 LED LAN 1~4	10 Vypínaè
3 WAN (Internet) LED	11 Botón Restablecer
4 LED de 2,5 G	12 Puertos USB 3.2 Gen 1
5 LED de 2,4 GHz	13 2,5G puerto
6 LED de 5 GHz	14 WAN (Internet) puerto
7 LED de alimentación	15 LAN 1~4 puertos
8 Botón Activar/Desactivar LED	16 Botón WPS

Ubicar el router inalámbrico

Para conseguir la mejor transmisión de señal inalámbrica entre el router inalámbrico y los dispositivos de red conectados a él, asegúrese de:

- Colocar el router inalámbrico en un área centralizada para conseguir la máxima cobertura inalámbrica para los dispositivos de red.
- Mantenga el dispositivo alejado de obstáculos metálicos y de la luz solar directa.
- Mantenga el producto alejado de dispositivos WiFi de 802.11g o 20 MHz, equipos periféricos de 2,4 GHz, dispositivos Bluetooth, teléfonos inalámbricos, transformadores, motores de alto rendimiento, luces fluorescentes, hornos microondas, frigoríficos y otros equipos industriales para evitar interferencias o pérdidas de señal.
- Actualícese siempre a la versión de firmware más reciente. Visite el sitio Web de ASUS en <http://www.asus.com> para obtener las actualizaciones de firmware más recientes.
- Oriente las antenas tal y como muestra la siguiente ilustración.

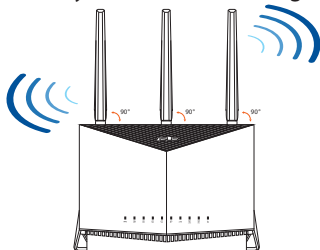

NOTAS:

- Utilice únicamente el cargador incluido con el paquete. Si usa otros adaptadores, el dispositivo puede resultar dañado.
- **Especificaciones:**

Adaptador de alimentación de CC	Salida de CC: +19 V con una corriente máxima de 2,37 A Salida de CC: +19,5 V con una corriente máxima de 2,31 A		
Temperatura de funcionamiento	0~40°C	Almacenamiento	0~70°C
Humedad de funcionamiento	50~90%	Almacenamiento	20~90%

Preparar el módem

1. **Desenchufe la alimentación del módem de cable o DSL. Si tiene una batería de reserva, quítela.**

NOTA: Si utiliza DSL para Internet, necesitará el nombre de usuario y la contraseña de su proveedor de servicio de Internet (ISP) para configurar adecuadamente el router.

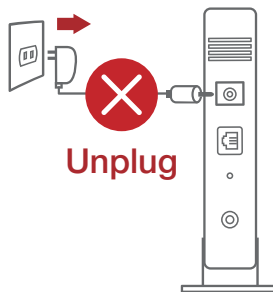

2. **Conecte el módem al router con el cable de red proporcionado.**



3. **Encienda su módem de cable o DSL.**
4. **Compruebe las luces de los LED del módem de cable o DLS para asegurarse de que la conexión está activa.**

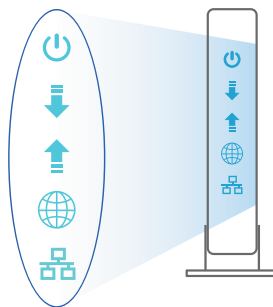

Configurar el RT-AX86U

Puede configurar el RT-AX86U a través de la conexión cableada o inalámbrica.

A. Conexión cableada

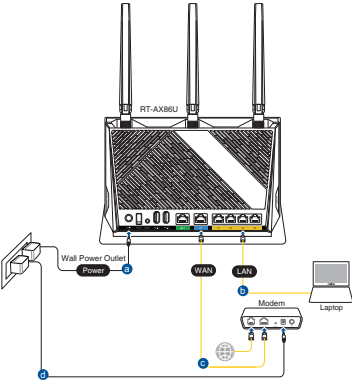
1. Enchufe el router a una toma de corriente eléctrica y enciéndalo. Conecte el cable de red desde el equipo a un puerto LAN del router.
- 
2. La GUI Web se inicia automáticamente cuando abre un explorador Web. Si no se inicia automáticamente, escriba <http://router.asus.com>.
 3. Configure una contraseña para el router para evitar el acceso no autorizado.

Login Information Setup

Change the router password to prevent unauthorized access to your ASUS wireless router.

Router Login Name	<input type="text" value="admin"/>
New Password	<input type="password"/>
Retype Password	<input type="password"/> <input type="checkbox"/> Show password

B. Conexión inalámbrica

1. Enchufe el router a una toma de corriente eléctrica y enciéndalo.

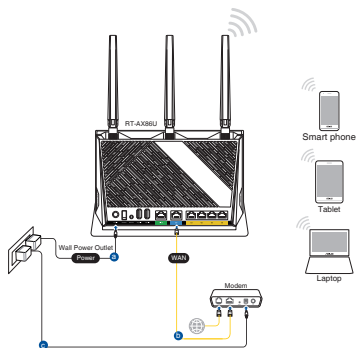

2. **Conéctese al nombre de red (SSID) mostrado en la etiqueta del producto que se encuentra en la parte posterior del router. Para mejorar la seguridad de la red, cambie a un SSID único y asigne una contraseña.**

Nombre Wi-Fi (SSID):	ASUS_XX
----------------------	---------

- * **XX** y hace referencia a los dos últimos dígitos de la dirección MAC de 2,4 GHz. Puede encontrarlo en la etiqueta situada en la parte posterior del RT-AX86U.

3. **Para configurar su router puede elegir tanto la GUI web como la aplicación ASUS Router.**

- a. **Configuración mediante GUI web**

- **La GUI Web se inicia automáticamente cuando abre un explorador Web. Si no se inicia automáticamente, escriba <http://router.asus.com>.**
- **Configure una contraseña para el router para evitar el acceso no autorizado.**

Login Information Setup

Change the router password to prevent unauthorized access to your ASUS wireless router.

Router Login Name

New Password

Retype Password Show password

b. Configuración mediante la app

Descargue la aplicación ASUS Router para configurar su router a través de su dispositivo móvil.



ASUS
Router



- Encienda la wifi en su dispositivo móvil y conéctelo a su red de Blue Cave.
- Siga las instrucciones de configuración de la aplicación ASUS Router para completar la configuración.



Recordar la configuración del router inalámbrico

- Recuerde la configuración inalámbrica cuando complete la configuración del router.

Nombre del router:	Contraseña:
SSID de red de 2,4 GHz:	Contraseña:
SSID de red de 5 GHz :	Contraseña:

Preguntas más frecuentes (P+F)

1. ¿De qué otros recursos dispongo para obtener más información acerca del router inalámbrico?
 - El sitio web de soporte técnico: <https://www.asus.com/support>
 - Línea Directa: Consulte el número de la línea telefónica de soporte técnico en esta Guía de inicio rápido.
 - Puede obtener el manual de usuario en línea en <https://www.asus.com/support>

Networks Global Hotline Information

Area	Country/ Region	Hotline Number	Service Hours
Europe	Cyprus	800-92491	09:00-13:00 ; 14:00-18:00 Mon-Fri
	France	0033-170949400	09:00-18:00 Mon-Fri
	Germany	0049-1805010920	09:00-18:00 Mon-Fri
		0049-1805010923 (component support)	10:00-17:00 Mon-Fri
		0049-2102959911 (Fax)	
	Hungary	0036-15054561	09:00-17:30 Mon-Fri
	Italy	06 97626662	09:00-13:00 ;
			14:00-18:00 Mon-Fri
	Greece	00800-44142044	09:00-13:00 ;
			14:00-18:00 Mon-Fri
	Austria	0043-820240513	09:00-18:00 Mon-Fri
	Netherlands/ Luxembourg	0031-591570290	09:00-17:00 Mon-Fri
	Belgium	0032-78150231	09:00-17:00 Mon-Fri
	Norway	0047-2316-2682	09:00-18:00 Mon-Fri
	Sweden	0046-858769407	09:00-18:00 Mon-Fri
	Finland	00358-969379690	10:00-19:00 Mon-Fri
	Denmark	0045-38322943	09:00-18:00 Mon-Fri
	Poland	0048-225718040	08:30-17:30 Mon-Fri
	Spain	0034-902889688	09:00-18:00 Mon-Fri
	Portugal	00351-707500310	09:00-18:00 Mon-Fri
	Slovak Republic	00421-232162621	08:00-17:00 Mon-Fri
	Czech Republic	00420-596766888	08:00-17:00 Mon-Fri
	Switzerland-Ger- man	0041-848111010	09:00-18:00 Mon-Fri
Switzer- land-French	0041-848111014	09:00-18:00 Mon-Fri	
Switzerland-Ital- ian	0041-848111012	09:00-18:00 Mon-Fri	
United Kingdom	0044-1442265548	09:00-17:00 Mon-Fri	
Ireland	0035-31890719918	09:00-17:00 Mon-Fri	
Russia and CIS	008-800-100-ASUS	09:00-18:00 Mon-Fri	
Ukraine	0038-0445457727	09:00-18:00 Mon-Fri	

Networks Global Hotline Information

Area	Country/ Region	Hotline Numbers	Service Hours
Asia-Pacific	Australia	1300-278788	09:00-18:00 Mon-Fri
	New Zealand	0800-278788	09:00-18:00 Mon-Fri
	Japan	0800-1232787 0081-570783886 (Non-Toll Free)	09:00-19:00 Mon-Sun 09:00-19:00 Mon-Sun
	Korea	0082-215666868	09:30-17:00 Mon-Fri
	Thailand	0066-24011717 1800-8525201	09:00-18:00 Mon-Fri
	Singapore	0065-64157917 0065-67203835 (Repair Status Only)	11:00-19:00 Mon-Fri 11:00-19:00 Mon-Fri 11:00-13:00 Sat
	Malaysia	1300-88-3495	9:00-18:00 Mon-Fri
	Philippine	1800-18550163	09:00-18:00 Mon-Fri
	India	1800-2090365	09:00-18:00 Mon-Sat
	India(WL/NW)	1800-2090365	09:00-21:00 Mon-Sun
	Indonesia	0062-2129495000 500128 (Local Only)	09:30-17:00 Mon-Fri 9:30 – 12:00 Sat
	Vietnam	1900-555581	08:00-12:00 13:30-17:30 Mon-Sat
	Hong Kong	00852-35824770	10:00-19:00 Mon-Sat
	Taiwan	0800-093-456; 02-81439000	9:00-12:00 Mon-Fri; 13:30-18:00 Mon-Fri
Americas	USA	1-812-282-2787	8:30-12:00 EST Mon-Fri
	Canada	1-812-282-2787	9:00-18:00 EST Sat-Sun
	Mexico	001-8008367847	08:00-20:00 CST Mon-Fri 08:00-15:00 CST Sat
	Brazil	4003 0988 (Capital) 0800 880 0988 (demais localidades)	9:00am-18:00 Mon-Fri

Networks Global Hotline Information

Area	Country/ Region	Hotline Numbers	Service Hours
Middle East + Africa	Egypt	800-2787349	09:00-18:00 Sun-Thu
	Saudi Arabia	800-1212787	09:00-18:00 Sat-Wed
	UAE	00971-42958941	09:00-18:00 Sun-Thu
	Turkey	0090-2165243000	09:00-18:00 Mon-Fri
	South Africa	0861-278772	08:00-17:00 Mon-Fri
	Israel	*6557/00972-39142800 *9770/00972-35598555	08:00-17:00 Sun-Thu 08:30-17:30 Sun-Thu
Balkan Countries	Romania	0040-213301786	09:00-18:30 Mon-Fri
	Bosnia Herzegovina	00387-33773163	09:00-17:00 Mon-Fri
	Bulgaria	00359-70014411 00359-29889170	09:30-18:30 Mon-Fri 09:30-18:00 Mon-Fri
	Croatia	00385-16401111	09:00-17:00 Mon-Fri
	Montenegro	00382-20608251	09:00-17:00 Mon-Fri
	Serbia	00381-112070677	09:00-17:00 Mon-Fri
	Slovenia	00368-59045400 00368-59045401	08:00-16:00 Mon-Fri
Baltic Countries	Estonia	00372-6671796	09:00-18:00 Mon-Fri
	Latvia	00371-67408838	09:00-18:00 Mon-Fri
	Lithuania-Kaunas	00370-37329000	09:00-18:00 Mon-Fri
	Lithuania-Vilnius	00370-522101160	09:00-18:00 Mon-Fri



NOTES:

- UK support e-mail: **network_support_uk@asus.com**
- For more information, visit the ASUS support site at: **<https://www.asus.com/support/>**

ASUS Recycling/Takeback Services

ASUS recycling and takeback programs come from our commitment to the highest standards for protecting our environment. We believe in providing solutions for you to be able to responsibly recycle our products, batteries, other components, as well as the packaging materials. Please go to <http://csr.asus.com/english/Takeback.htm> for the detailed recycling information in different regions.

REACH

Complying with the REACH (Registration, Evaluation, Authorisation, and Restriction of Chemicals) regulatory framework, we published the chemical substances in our products at ASUS REACH website at <http://csr.asus.com/english/REACH.htm>

Federal Communications Commission Statement

This device complies with Part 15 of the FCC Rules. Operation is subject to the following two conditions:

- This device may not cause harmful interference.
- This device must accept any interference received, including interference that may cause undesired operation.

This equipment has been tested and found to comply with the limits for a class B digital device, pursuant to part 15 of the FCC Rules. These limits are designed to provide reasonable protection against harmful interference in a residential installation.

This equipment generates, uses and can radiate radio frequency energy and, if not installed and used in accordance with the instructions, may cause harmful interference to radio communications. However, there is no guarantee that interference will not occur in a particular installation. If this equipment does cause harmful interference to radio or television reception, which can be determined by turning the equipment off and on, the user is encouraged to try to correct the interference by one or more of the following measures:

- Reorient or relocate the receiving antenna.
- Increase the separation between the equipment and receiver.
- Connect the equipment into an outlet on a circuit different from that to which the receiver is connected.

- Consult the dealer or an experienced radio/TV technician for help.



WARNING! Any changes or modifications not expressly approved by the party responsible for compliance could void the user's authority to operate the equipment.

Prohibition of Co-location

This device and its antenna(s) must not be co-located or operating in conjunction with any other antenna or transmitter.

IMPORTANT NOTE:

Radiation Exposure Statement: This equipment complies with FCC radiation exposure limits set forth for an uncontrolled environment. End users must follow the specific operating instructions for satisfying RF exposure compliance. To maintain compliance with FCC exposure compliance requirement, please follow operation instruction as documented in this manual. This device is restricted for indoor use.



WARNING! This equipment must be installed and operated in accordance with provided instructions and the antenna(s) used for this transmitter must be installed to provide a separation distance of at least 26 cm from all persons and must not be co-located or operating in conjunction with any other antenna or transmitter.

Compliance Statement of Innovation, Science and Economic Development Canada (ISED)

This device complies with Innovation, Science and Economic Development Canada licence exempt RSS standard(s). Operation is subject to the following two conditions: (1) this device may not cause interference, and (2) this device must accept any interference, including interference that may cause undesired operation of the device.

Operation in the band 5150–5250 MHz is only for indoor use to reduce the potential for harmful interference to co-channel mobile satellite systems.

CAN ICES-3(B)/NMB-3(B)

Radio Frequency (RF) Exposure Information

The radiated output power of the ASUS Wireless Device is below the Innovation, Science and Economic Development Canada radio frequency exposure limits. The ASUS Wireless Device should be used in such a manner such that the potential for human contact during normal operation is minimized.

This equipment should be installed and operated with a minimum distance of 31 cm between the radiator any part of your body.

This device has been certified for use in Canada. Status of the listing in the Innovation, Science and Economic Development Canada's REL (Radio Equipment List) can be found at the following web address:

http://www.ic.gc.ca/eic/site/ceb-bhst.nsf/eng/h_tt00020.html

Additional Canadian information on RF exposure also can be found at the following web:

<https://www.ic.gc.ca/eic/site/smt-gst.nsf/eng/sf08792.html>

Déclaration de conformité de Innovation, Sciences et Développement économique Canada (ISED)

Le présent appareil est conforme aux CNR d'Innovation, Sciences et Développement économique Canada applicables aux appareils radio exempts de licence. L'exploitation est autorisée aux deux conditions suivantes : (1) l'appareil ne doit pas produire de brouillage, et (2) l'utilisateur de l'appareil doit accepter tout brouillage radioélectrique subi, même si le brouillage est susceptible d'en compromettre le fonctionnement.

La bande 5150 – 5250 MHz est réservée uniquement pour une utilisation à l'intérieur afin de réduire les risques de brouillage préjudiciable aux systèmes de satellites mobiles utilisant les mêmes canaux.

CAN ICES-3(B)/NMB-3(B)

Informations concernant l'exposition aux fréquences radio (RF)

La puissance de sortie émise par cet appareil sans fil est inférieure à la limite d'exposition aux fréquences radio d'Innovation, Sciences et Développement économique du Canada (ISED). Utilisez l'appareil sans fil de façon à minimiser les contacts humains lors d'un fonctionnement normal.

Cet équipement doit être installé et utilisé avec un minimum de 31 cm de distance entre la source de rayonnement et votre corps.

L'utilisation de cet appareil est autorisée au Canada. Pour consulter l'entrée correspondant à l'appareil dans la liste d'équipement radio (REL - Radio Equipment List) d'Innovation, Sciences et Développement économique du Canada, rendez-vous sur :

http://www.ic.gc.ca/eic/site/ceb-bhst.nsf/eng/h_tt00020.html

Pour des informations supplémentaires concernant l'exposition aux fréquences radio au Canada, rendez-vous sur : <https://www.ic.gc.ca/eic/site/smt-gst.nsf/eng/sf08792.html>

This radio transmitter [3568A-RTAXI600] has been approved by Innovation, Science and Economic Development Canada to operate with the antenna types listed below, with the maximum permissible gain indicated. Antenna types not included in this list that have a gain greater than the maximum gain indicated for any type listed are strictly prohibited for use with this device.

Le présent émetteur radio (3568A-RTAXI600) a été approuvé par Innovation, Sciences et Développement économique Canada pour fonctionner avec les types d'antenne énumérés ci-dessous et ayant un gain admissible maximal d'antenne. Les types d'antennes non inclus dans cette liste qui ont un gain supérieur au gain maximal indiqué pour tout type listé sont strictement interdits pour une utilisation avec cet appareil.

Set	Ant.	Brand	P/N	Type	Connector	Antenna Gain (dBi)				
						2.4GHz Band 1	5GHz Band 1	5GHz Band 2	5GHz Band 3	5GHz Band 4
1	1	WHA YU	C660-510490-A	Dipole		1.66	1.86	1.86	1.90	1.84
	2									
	3									
	4	WHA YU	C660-510390-A	PCB	-	2.90	2.90	3.00	2.52	
2	1	WHA YU	C660-510492-A	Dipole		1.52	1.41	1.45	1.72	1.74
	2									
	3									
	4	WHA YU	C660-510390-A	PCB	-	2.90	2.90	3.00	2.52	
3	1	WHLSIN	RFDPAA1415005BLB802	Dipole		1.52	1.66	1.76	1.82	1.65
	2									
	3									
	4	WHLSIN	RFPCA302603IM5B301	PCB	-	2.17	2.30	2.20	2.49	

The maximum antenna gain permitted for devices in the bands 5250-5350 MHz and 5470-5725 MHz shall be such that the equipment still complies with the e.i.r.p. limit.

le gain maximal d'antenne permis pour les dispositifs utilisant les bandes 5250-5350 MHz et

5470-5725 MHz doit se conformer à la limite de p.i.r.e.

The maximum antenna gain permitted for devices in the band 5725-5850 MHz shall be such that the equipment still complies with the e.i.r.p. limits specified for point-to-point and non-point-to-point operation as appropriate.

le gain maximal d'antenne permis (pour les dispositifs utilisant la bande 5725-5850 MHz)

doit se conformer à la limite de p.i.r.e. spécifiée pour l'exploitation point à point et non point à point, selon le cas.

For indoor use only.

Pour une utilisation en intérieur uniquement.

